

# PROTOTYPE EQUIPMENT FOR COMMERCIAL PRESSURE-INJECTION OF AQUEOUS GROWTH REGULATORS INTO TREES<sup>1</sup>

by G.K. Brown<sup>1</sup>

*Additional index words: Injection equipment, growth regulator, tree growth.*

**Abstract.** An equipment system was developed for injection of a low vol of concd aqueous growth regulator solution into shade trees for sprout-regrowth control. The injection equipment is air powered and injects a precise vol into each injection site. Vol and pressure can be easily adjusted. The injectors are small diam and, therefore, easily force fitted into drilled holes and easily removed by hand. Tree disfigurement is not significant. The system has been field tested on several tree species and is at a commercial-prototype stage. Its design is described in detail.

The control of tree growth along powerline rights-of-way is a major expense of electric utilities (1). Growth that can potentially contact a powerline is removed by manual pruning, which must presently be repeated at intervals of 1 to 3 years for the removal of regrowth and maintenance of proper clearance. In 1973 the Electric Power Research Institute (EPRI) and the Agricultural Research Service, U.S. Department of Agriculture, entered into a cooperative agreement to develop new methods and chemicals for the control of tree regrowth. At the beginning of the project the research team identified growth regulator injection as the method to be emphasized because injection should prevent unintended ecological effects (1) and because recent research had demonstrated that some tree diseases could be suppressed or cured by

injecting the tree trunk with fungicides (2, 8).

The control of tree regrowth along powerlines by growth regulator injection will probably involve repeated treatment of the same tree every few years. Most trees will be in public view, either in private yards or along urban streets. The injection methods and equipment must, therefore, minimize disfigurement of the tree trunk and risk of decay at the injection site, in addition to meeting requirements of safety, effectiveness, and economy.

Tree injection is not new. Other researchers have found that injection was used as early as 1158 (10). The first report on tree injection by an American researcher reportedly appeared in 1897, although many German, French, and Russian studies were published from 1840-1900 (11). In these early studies, chemicals were usually introduced into the tree by natural uptake through cut or drilled holes. Since 1900, publications dealing with tree injection methods or results have become extensive (see list of supplemental literature), and a complete review is beyond the scope of this report. However, only recently have researchers undertaken systems design and development efforts to provide commercially feasible methods for quickly pressure-injecting large numbers of trees with chemicals (e.g., 3,5,6,7,8,9,12).

1. This article describes a technological advancement made in the course of a research project under a cooperative agreement between the Electric Power Research Institute, Inc. (EPRI), and the Agricultural Research Service, U.S. Department of Agriculture (ARS-USDA). The development was made under the agreement by an ARS employee, G.K. Brown.

The foregoing notwithstanding, EPRI, its members, any of them, and any persons acting on behalf of them, make no warranty or representation, expressed or implied, with respect to the accuracy, completeness, or usefulness of the information contained in the following article, or that the use of any information, apparatus, method, or process described in the following article may not infringe upon privately owned rights, and assume no liabilities with respect to the use of any information, apparatus, method or process disclosed in the following article or for damages resulting from such use.

Mention of a trade name or proprietary product does not constitute a guarantee or warranty of the product by the U.S. Department of Agriculture and does not imply its approval to the exclusion of other products that may also be suitable.

2. The author is Research Leader and Agricultural Engineer, Agricultural Research Service, U.S. Department of Agriculture, Agricultural Engineering Department, Michigan State University, East Lansing, MI 48824. He was formerly with the Nursery Crops Research Laboratory, ARS-USDA, Delaware, OH.

Wuertz, D.E. and C.L. Wilson (Control of elm tree regrowth through pressure injection of growth regulators. Unpublished report, 1973. Nursery Crops Research Lab. 10p.) used injection techniques similar to those of Southwick (13) and Himelick (7) in preliminary growth regulator injection studies conducted in 1973 on 11-year old American elm (*Ulmus americana* L.). A small engine-powered sprayer served as the pressure source. About 2 liters (1/2 gal) of solution was injected into the trunk of each tree through lag-screw injectors screwed into three drilled holes of 9.5 mm (3/8 inch) diam and 64 mm (2.5 inch) depth. The reduction in regrowth was encouraging.

In 1974 the author initiated engineering studies at Delaware to develop simple, portable and precise equipment for injecting growth regulators into the trunks of trees growing along powerline rights-of-way. This report presents a summary of that work and describes the resulting prototype equipment. The results for parallel field studies on tree response to growth regulator injection are given in another report (4).

The initial engineering studies were designed for determination of the effect of injector type, injection hole size, injection pressure, tree diam, and leaf water potential on injection rate (i.e., the rate at which water can be injected into the tree). I found that injection rate was higher for drilled holes than for punched holes, increased as hole size increased, increased as injection pressure increased, increased as tree diam increased, and was not significantly affected by leaf moisture (3). Injection rate at alternate sites on the tree ranged from  $\pm$  25 to 40% of the mean rate for the tree and decreased as the vol injected increased. I hypothesized that, to uniformly reduce regrowth, an equal vol of chemical solution should be injected at each site. The practical max limit of injection pressure for American elm in these tests was found to be about 14 kg/cm<sup>2</sup> (200 psi). Higher pressure resulted in bark blowouts on some trees.

To obtain additional guidance on injector design, I arranged for Dr. Alex Shigo (Senior Plant Pathologist, Forest Service, USDA, Durham, NH) to examine American elm trees previously in-

jected by use of lag-screw injectors. Those injectors often split the xylem tissue and loosened some cambial tissues as they were screwed into the drilled hole. He recommended that the lag-screw injector be replaced by something less damaging and that the size of the injection hole be minimized to shorten healing time, reduce risk of decay, and minimize internal compartmentalization.

## EQUIPMENT AND METHODS

**Injectors.** In 1975 I designed and evaluated two small-diam force-fit injectors for use in drilled holes. When a low vol of solution was used, injection rates were satisfactory for tree species having a vessel diam and density similar to those of American sycamore (*Platanus occidentalis* L.), cottonwood (*Populus deltoides* Bartr. ex Marsh.) and American elm (Fig. 1). The injector with the larger of the two diams gave satisfactory injection rates of species having low vessel density. Injection rates for conifers were not satisfactory in any tests. The small-diam injectors were easily pushed into and pulled from the drilled holes with a twisting motion, and they operated safely without leakage if inserted to an adequate depth (at least 1.25 cm or 0.5 inch). The withdrawal force can be designed to be several times greater than the hydraulic force acting to push the injector from the hole (Fig. 2).

Based on observations, healing time was much faster and the incidence of decay and internal compartmentalization was much less than those resulting from use of the lag-screw injector. Silver maple (*Acer saccharinum* L.) with smooth bark has shown a tendency for the bark to split vertically from the injection hole. Although this problem was not eliminated by the small injector, it was reduced (Fig. 3).

**Syringe Modification.** I modified a 50-ml veterinarian's syringe (Fig. 4) to provide a simple method for injecting a precise vol of growth regulator solution. A firm squeeze produces an injection pressure of about 7 kg/cm<sup>2</sup> (100 psi). Smaller bore syringes can be used for producing higher pressures. The syringe method is simple, but it is too slow for general use in an injection program for the control of regrowth along

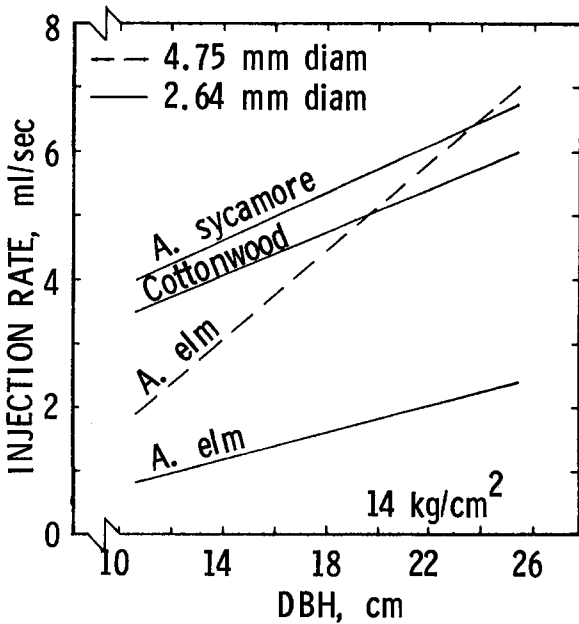

Fig. 1. Mean injection rate per site, observed at a constant pressure of 14 kg/cm<sup>2</sup> for American sycamore, American elm, and cottonwood for hole diam of 2.64 or 4.75 mm, depth of 64 mm, and tree diam of 10 to 26 cm at about 1.4 m above the ground, Delaware, OH, July 1975.

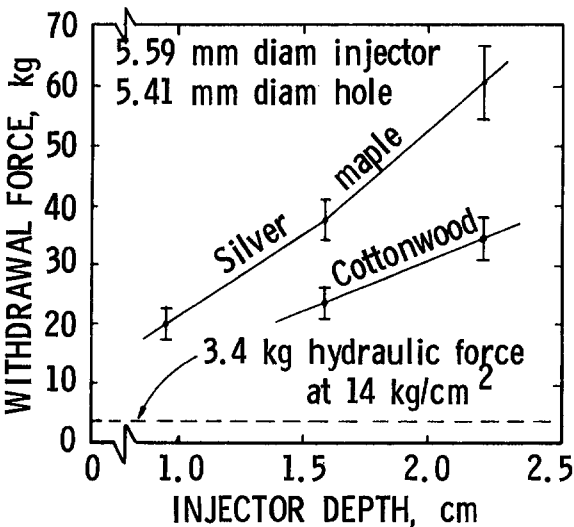

Fig. 2. Mean withdrawal force vs. injector depth in silver maple and cottonwood for a 5.59-mm-diam injector force-fitted into a 5.41-mm-diam drilled hole, Delaware, OH, May 1977. The symbol I represents  $\pm 1$  SD of the values of 12 observed forces from their mean. Hydraulic force acting to push the injector from the hole is only 3.4 kg when injection pressure is 14 kg/cm<sup>2</sup>.

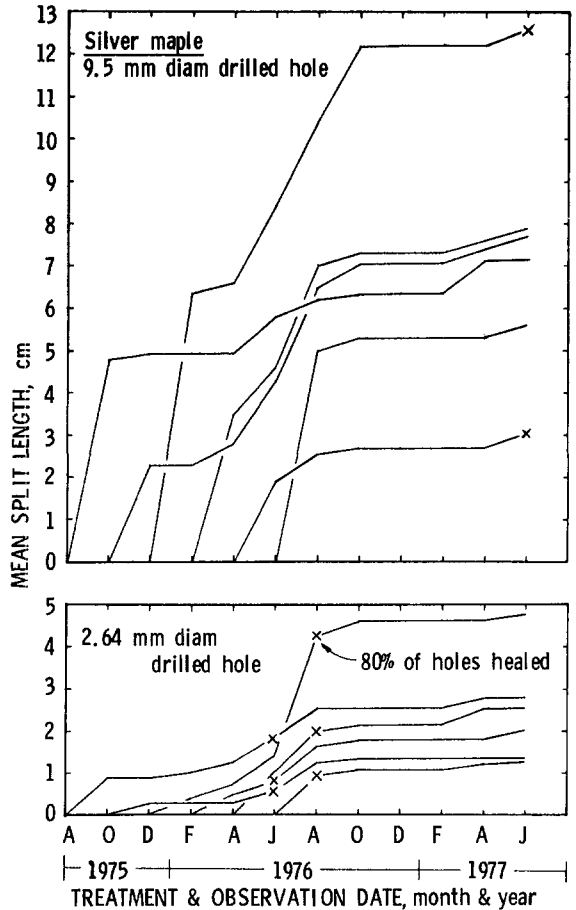

Fig. 3. Mean length of bark split on smooth-bark silver maple for drilled holes with 9.5-mm and 2.64-mm diams vs. month of treatment and observation. The symbol "x" represents the first date when 80% or more of the holes were closed.

powerlines.

Wilson et al. (15) adapted this syringe method to inject water soluble fungicides into American elm for the experimental control of Dutch elm disease. Sterrett and Creager (14) also adapted the syringe method for injecting aqueous solutions into seedlings and small branches.

**Prototype Equipment.** The design of the prototype injection system makes use of the advantages of the small-diam force-fit injectors and a low vol of concd solution.

The system is enclosed in an aluminum sheet metal housing (Fig. 5) that is 20 cm (8 inches) wide, 50 cm (20 inches) long, and 50 cm high. Most system parts are aluminum for min wt.

However, all parts of the injection circuit are stainless steel or plastic for protection against corrosive growth-regulator solutions. Total wt is about 18 kg (40 lb).

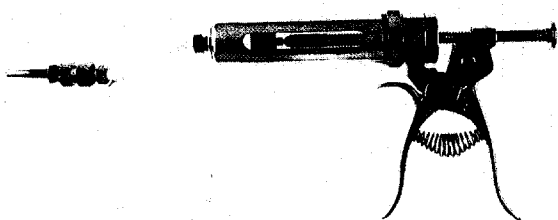

Fig. 4. Pistol-grip veterinarian's syringe (50-ml vol), modified for exploratory injection studies.

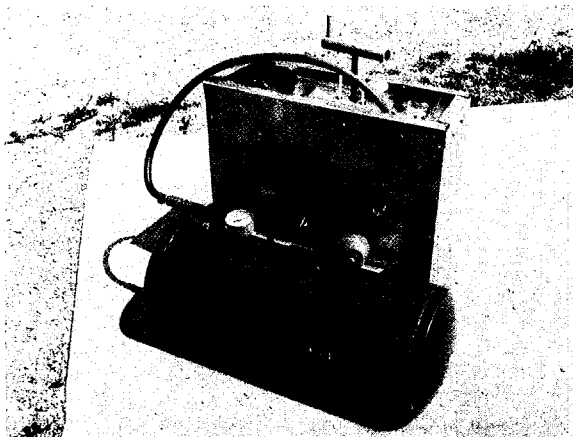

Fig. 5. Injection system, consisting of injection equipment housing, battery-powered drill, and portable air tank.

The injectors are made from stainless steel tubing and one-half of a stainless steel hex nipple (Fig. 6,7). The 5.59-mm (0.220-inch) diam was selected for use in the 1976 program so that a satisfactory injection rate could be achieved on all species. The 0.18-mm (0.007-inch) force-fit (diam of injector minus diam of drilled hole) permitted safe operation without leakage and did not cause splitting of the xylem or loosening of the cambial tissue.

Each injector has its own injection circuit, injection cylinder, and pneumatic power control circuit (Fig. 8). The injection cylinder is made of

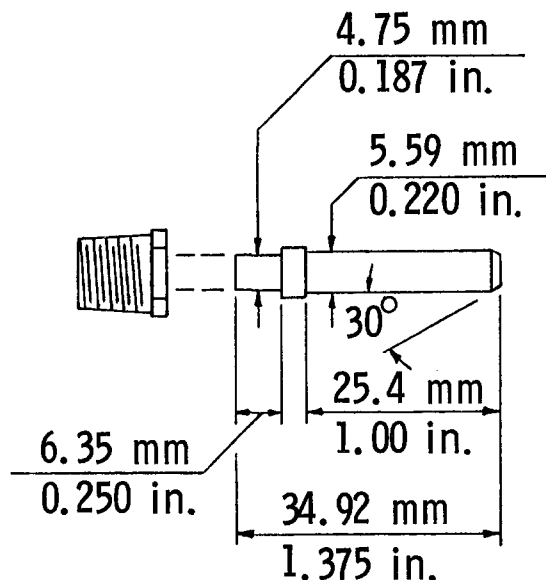

Fig. 6. Construction details for injector, for 5.41-mm (0.213-inch) diam drilled hole, used in 1976 and 1977 field tests. Machine from type 304 stainless steel tube, 6.35-mm (0.250-inch) outside diam X 2.13-mm (0.084-inch) wall. Insert into one-half of a 3.175-mm (0.152-inch) pipe hex nipple, type 316 stainless steel, and silver-solder together.

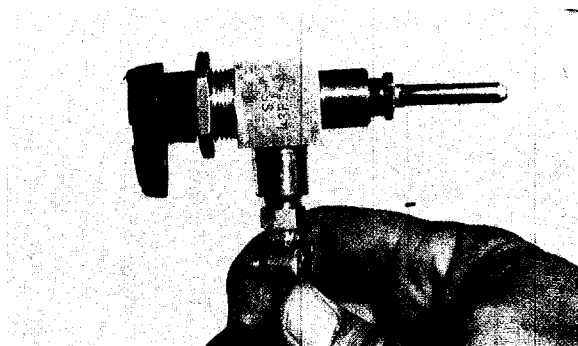
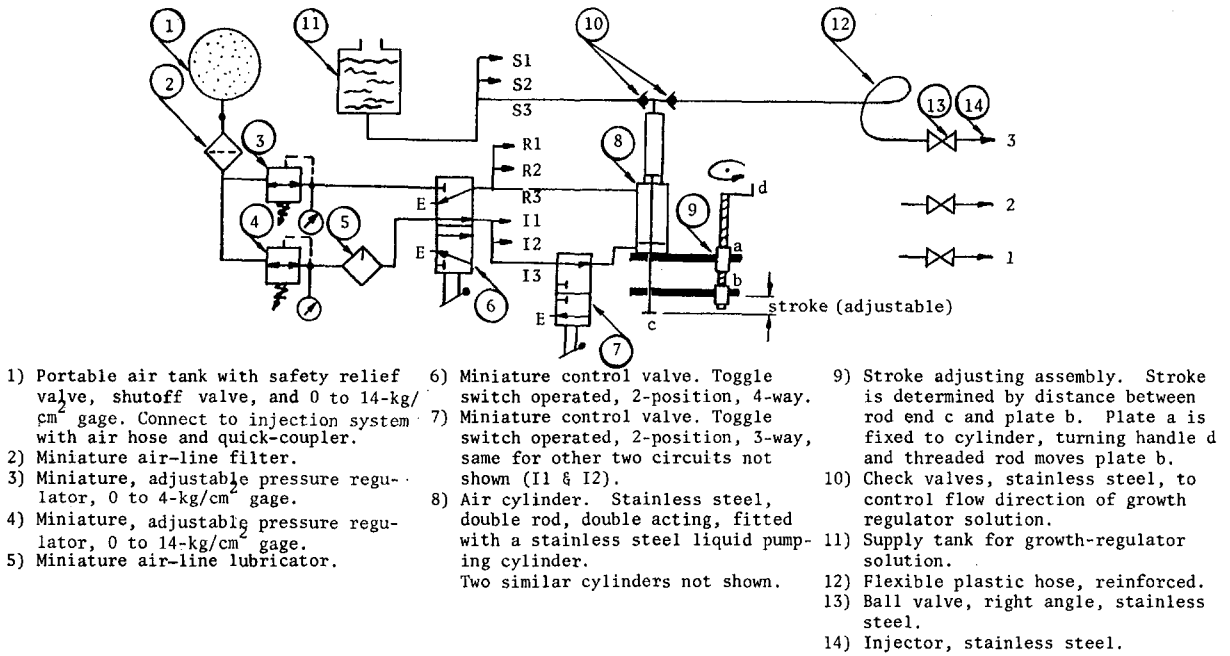

Fig. 7. Finished injector and ball-valve assembly.

stainless steel and is a combination design for conversion of low air pressure to high water pressure. The theoretical pressure ratio between the water and air ends of the cylinder is 3.26 to 1. The water end can displace a max vol of 40 ml per cycle and can be limited to any vol between 0 and 40 ml by the stroke adjustment control. One can adjust the stroke easily by turning a threaded rod. The vol selected is indicated directly to an accuracy of 1 ml by color-coded rings machined into the shaft of the stroke adjustment control (Fig. 9), and the position of each cylinder



**Fig. 8.** Schematic details and descriptive parts list for the pneumatic and hydraulic circuits of the prototype injection equipment.

is shown by the position indicator rod. When more than 40 ml per injector are to be introduced, multiple cycles of the injection cylinder are used.

The supply of growth regulator solution is carried in a 1.5 liter tank, made from a 76-mm (3-inch) inside diam X 330-mm (13-inch) plastic tube, located within the housing. The tank can be easily refilled or removed for draining and flushing.

The air supply is carried in a 45 liter (12 gal), portable 7 kg/cm<sup>2</sup> (100 psi) air tank, which can be connected to the injection system via a pneumatic quick coupler. The portable air tank can be quickly recharged from a larger air tank carried on the service truck. If the larger tank is of 300-liter (80-gal) capacity and initially charged to 10.5 kg/cm<sup>2</sup> (150 psi), it will supply enough power for a week of injection work by a typical pruning crew.

Three injection holes 5.41 mm (0.213 inch) in diam X 63 mm (2.5 inches) deep are drilled into the trunk of each tree with a portable, battery-powered drill. (We used a Black & Decker 9090/

1941, 750 rpm, 1-hr recharge.) The holes are equally spaced around the tree trunk about 1 m (3.3 ft) above ground and are drilled horizontally at a 45 degree angle to the trunk diam so the growth regulator will be injected into only the outer rings of sapwood.

**Equipment Performance.** The injection system was used in Ohio in 1976 for the injection of over 400 topped American sycamore, silver maple, Siberian elm (*Ulmus pumila* L.), red oak (*Quercus rubra* L.) and American elm of the 10- to 40-cm (4- to 16-inch) diam. Injection (solution) pressures of 7 to 14 kg/cm<sup>2</sup> (100 to 200 psi) were used. The injection system operated without problems, and no bark blowouts, injector leakage, or injector blowouts occurred. The injector could be removed from the sycamore and elm immediately, without back-flow, but a 2-min wait was required with the other species.

During April and May 1977, the system was used in additional field experiments in Ohio, Pennsylvania, Georgia, and California on American sycamore, silver maple, Siberian elm, water oak

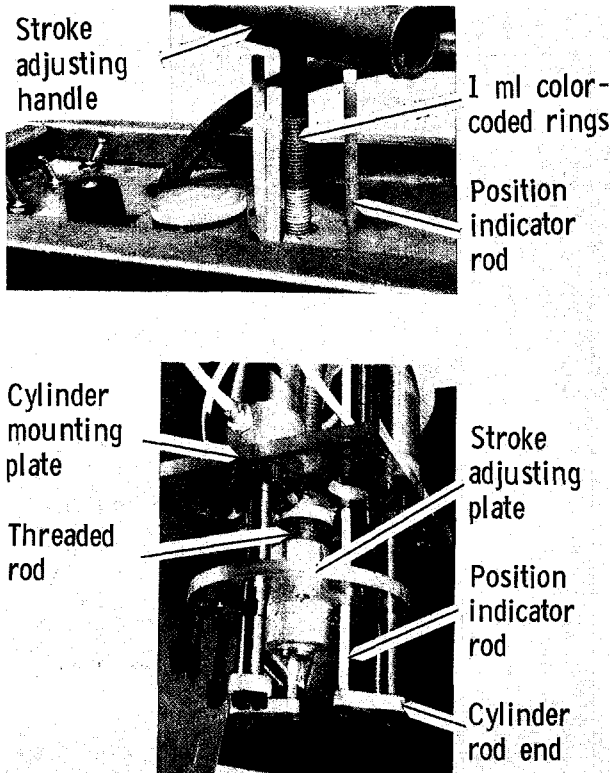

**Fig. 9.** Details of stroke adjustment control. Adjustment handle, color-coded rings for direct indication of vol to be injected, and cylinder position indicator rod (top). Cylinder mounting plate, threaded rod, stroke adjusting plate, cylinder position indicator rod, and cylinder rod end (bottom).

(*Quercus nigra* L.), red oak, shamel ash (*Fraxinus uhdei* (Wenzig) Lingelsh.) and eucalyptus (*Eucalyptus globulus* Labill.). In all locations and with all species, the system again operated without problems.

### Anticipated Commercial Utilization

The injection equipment and method are expected to be used commercially in the next few years if the results of field research continue to show that injected growth regulators can reduce tree growth and sprout development without causing unacceptable effects on the trees. The equipment may also be useful for injecting other types of chemicals into large numbers of trees.

The material and components used in the prototype equipment described have a retail cost of about \$800 (1976 prices). The purchase cost for a commercial unit for which components are obtained at wholesale costs should not exceed

\$1500. We anticipate a total injection cost per tree of \$2 to \$3, about 20% of which will be for the equipment.

Commercial utilization of the injection system will depend upon other factors besides continued success in field research and reasonable equipment cost. Its use must provide savings in pruning costs, the materials and method must be registered under the FIFRA, and use of the procedure must be acceptable to both the utility company and property owners involved. Most growth-regulator materials being used in our tests are those already cleared for foliar applications. The described procedure is not registered at this time, but several other injection procedures have been approved (e.g. to correct iron or zinc deficiencies in some shade trees, control some pests of shade trees, control Dutch elm disease, control lethal yellowing disease of coconut palm, and control pear decline).

### Literature Cited

- Abbott, R.E. 1976. *New concepts in utility arboriculture*. J. Arboriculture, 2(8):148-150.
- Anon. 1972. *To save a tree: new hope against Dutch elm disease*. Agr. Res., 21(3):11.
- Brown, G.K. and J.B. Bachelor. 1974. Engineering development of equipment for injecting chemicals into trees. Amer. Soc. Agr. Eng. Paper 74-1520, 10 p.
- Brown, G.K., W.F. Kwolek, D.E. Wuertz, G.A. Jumper, C.L. Wilson and S.R. Carr. 1977. *Regrowth reduction in American elm and sycamore by growth regulator injection*. J. Amer. Soc. Hort. Sci. (In press).
- Gibbs, J.N. and J. Dickinson. 1975. *Fungicide injection for the control of Dutch elm disease*. Forestry 48(2):165-178.
- Gregory, Garold F. and Thomas W. Jones. 1975. An improved apparatus for pressure-injecting fluid into trees. USDA For. Serv. Res. Note NE-214, 6 p.
- Himelick, E.B. 1972. *High pressure injection of chemicals into trees*. Arborist's News, 37(9):97-103.
- Jones, Thomas W. and Garold F. Gregory. 1971. An apparatus for pressure injection of solutions into trees. USDA For. Serv. Res. Paper NE-233, 7 p.
- Reil, Wilbur O. and James A. Buetel. 1976. *A pressure machine for injecting trees*. Calif. Agr. 30(12): 4-5.
- Roach, W.A. 1939. *Plant injection as a physiological method*. Ann. Bot. New Series 3:155-226.
- Rumbold, C. 1920. *Injection of chemicals into chestnut trees*. Amer. J. Bot. 7:1-20, 45-56.
- Sacks, R.M. G. Nyland, W.P. Hackett, R.J. Coffelt, J. DeBie and G. Giannini. 1977. *Pressurized injection of aqueous solutions into tree trunks*. Sci. Hortic. (In press).
- Southwick, Roy W. 1945. *Pressure injection of iron sulfate into citrus trees*. Proc. Amer. Soc. Hort. Sci. 46:27-31.

14. Sterrett, J.P. and R.A. Creager. 1977. *A miniature pressure injector for deciduous woody seedlings and branches*. HortScience 12(2): 156-158.
15. Wilson, C.L., R.A. Spotts and C.R. Semer, IV. 1977. *New injection equipment and fungicide for Dutch elm disease control*. Plant Dis. Rprtr. (In press).
15. May, Curtis. 1941. *Methods for tree injection*. Trees 4:7,10-12,14,16.
16. McCoy, R.E. 1972. *Remission of lethal yellowing in coconut palm treated with tetracycline antibiotics*. Plant Dis. Rprtr. 56:1019-1921.
17. McCoy, R.E. 1974. *Techniques for treatment of palm trees with antibiotics*. Proc. Fla. State Hort. Soc. 87:537-540.

### Supplemental Literature

1. Anon. 1972. *A new method to combat tree diseases*. USDA For. Serv., N.E. For. Expt. Sta., Upper Darby, PA, Photo Story No. 19, 4 p.
2. Baumgardt, John P. 1975. *Protect your shade and ornamental trees with chemicals that work from the inside out*. Grounds Maint. 10(11):28-30.
3. Clifford, D.R., P. Gendle and E.A. Fribbins. 1976. *Formulations for the control of Dutch elm disease*. Pestic. Sci. 7:91-96.
4. Collison, R.C., J.D. Harlan and Morgan P. Sweeney. 1932. *Direct tree injection in the study of tree nutrition problems*. N.Y. Agr. Expt. Sta. Tech. Bul. No. 192, 36 p.
5. Craighead, F.C. and R.A. St. George. 1938. *Experimental work with the introduction of chemicals into the sap stream of trees for the control of insects*. J. Forestry 36:26-34.
6. Delange, J.H. 1974. *A trunk injector for the application of growth regulators to citrus trees*. Agroplantae 6:17, 18.
7. Filer, T.H., Jr. 1973. *Pressure apparatus for injecting chemicals into trees*. Plant Dis. Rprtr. 57:338-341.
8. Goff, E.S. 1897. *The application of artificial root pressure on recently transplanted trees*. Annu. Rpt. Wis. Agr. Expt. Sta. 14:272-282.
9. Gregory, G.F., T.W. Jones and P. McWain. 1971. *Injection of benomyl into elm, oak, and maple*. USDA For. Serv. Res. Paper NE-232, 9 p.
10. Helburg, Lawrence B., Michael E. Schomaker and Ronald A. Morrow. 1973. *A new trunk injection technique for systemic chemicals*. Plant Dis. Rprtr. 57:513,514.
11. Helton, A.W. and K.G. Rohrbach. 1966. *Translocation of twelve fungicidal compounds injected into trees of Prunus domestica*. Phytopathology 56:933-939.
12. Jaynes, Richard A. and Neal K. Van Alfen. 1974. *Control of American chestnut blight by trunk injection with methyl-2-benzimidazole carbamate (MBC)*. Phytopathology 64:1479-1480.
13. Kadman, A. and A. Cohen. 1974. *A rapid method for curing chlorotic avocado trees*. Yearb. Calif. Avocado Soc. 56:159-165.
14. Kondo, E.S. 1972. *A method for introducing water-soluble chemicals into mature elms*. Can. For. Serv., Dept. Environ. Inform. Rpt. O-X-171, 11 p.
18. Pinkas, Y., E. Shabi, Z. Solel and A. Cohen. 1973. *Infiltration and translocation of thaibendazole in apple trees by means of a pressure injection technique*. Phytopathology 63:1166-1168.
19. Prasad, R. and D. Travnick. 1973. *Translocation of benomyl in elm (Ulmus americana L.)*. V. Distribution patterns in mature trees following trunk injection under high pressures. Chem. Contr. Res. Inst., Can. For. Serv., Dept. Environ. Inform. Rpt. CC-X-53.
20. Rogers, Harold T. 1975. *Tree injection*. Amer. Fruit Grower. 95(8):13-15.
21. Rumbold, C. 1915. *Methods of injecting trees*. Phytopathology 5:225-229.
22. \_\_\_\_\_ 1920. *Giving medicine to trees*. Amer. For. 26:359-263.
23. Sachs, R.M., W.P. Hackett and D. Weisser. 1973. *Soil and trunk injections of growth regulators*. HortScience 8(3):275 (Abstr.).
24. Schreiber, L.R. 1969. *A method for the injection of chemicals into trees*. Plant Dis. Rprtr. 53:764,765.
25. Schwarz, R.E. and S.P. Van Vuuren. 1971. *Decrease in fruit greening of sweet orange by trunk injection of tetracyclines*. Plant Dis. Rprtr. 55:747-750.
26. Shabi, E., Y. Pinkas and Z. Solel. 1974. *Distribution of benzimidazole fungicides following pressure injection into pear trees at several growth stages*. Phytopathology 64:963-966.
27. Smalley, E.B., C.J. Meyers, R.N. Johnson, B.C. Fluke, and R. Vieau. 1973. *Benomyl for practical control of Dutch elm disease*. Phytopathology 63:1239-1252.
28. Tehon, Leo R. and Homer L. Jacobs. 1939. *Experimental injection of hard maple saplings artificially infected with Verticillium Albo-Atrum R & R. Davey Tree Expert Co., Bul. 7. 31 p.*
29. Van Alfen, N.K. and G.S. Walton. 1974. *Pressure injection of benomyl and methyl-2-benzimidazole carbamate hydrochloride for control of Dutch elm disease*. Phytopathology 64:1231-1234.
30. Worley, R.E., R.H. Littrell and S.G. Polles. 1976. *Pressure trunk injection promising for pecan and other trees*. HortScience 11(6):590-591.

## ABSTRACT

Potter, H.S. 1977. **Drift control**. Agrichemical Age 20(5): 20-21.

Drift can be a limiting factor in low-volume applications of fungicides. The problem lies in the high percentage of very fine drops that result with low-volume applications. The major factors affecting drop size are spray pressure, size of nozzle orifice, and orientation of the nozzle in the airstream. Spray additives such as foams and thickeners have been used with some success to control drop size.